



ASSEMBLING THE BOOK: Gather together the dry bookblock, the cover and the headband material.

• glue headbands to the top and bottom of the spine by applying glue to the spine, **figure 20**. Make sure the embroidered bump faces towards the pages and extends just above the spine edge, **figure 21**.

• test the bookblock inside the book cover to see how it fits together before applying glue. Open the cover and remove the bookblock. Place the cover with the inside face up.

• insert a piece of scrap paper between the first and second page of the bookblock to protect the pages from glue, **figure 22**. Apply glue to the entire outside of the first page. Remove the scrap paper.

• glue the bookblock to one of the covers, making sure to leave approximately an $\frac{1}{8}$ " of the cover showing on the top, bottom, and outside edges, **figure 23**. The bookblock spine side should hang over the edge of the bookboard a little bit. Smooth down the glued page.

• insert a piece of scrap paper under the last page of the bookblock and apply glue to the entire outside of the page. Remove scrap paper.

• “close” the book cover by pulling the bookcloth spine tightly around book block spine and closing the unglued cover against the glued page. As with the front cover, there should be approximately an $\frac{1}{8}$ " showing on the top, bottom and outside edge.

• open the cover to smooth the glued paper. While the glue is still wet and the paper has a little give, open the book as far as it will open, **figure 24**. Close the book up and smooth down the glued pages.

• use the point of a bone folder to create a crease on the outside of the bookcloth between the spine and the front and back covers, **figure 25**.

• wrap the book in protective scrap paper and place it under weights overnight.

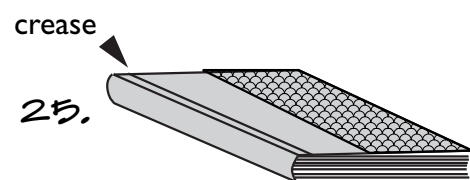
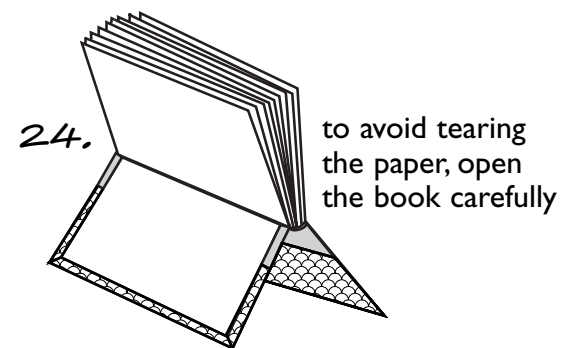
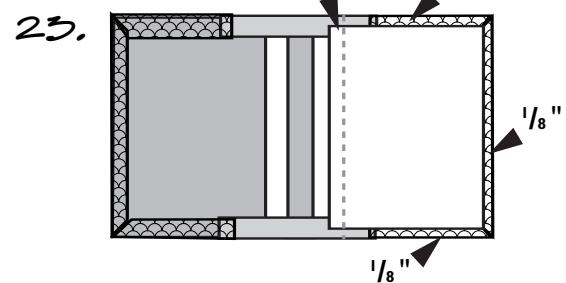
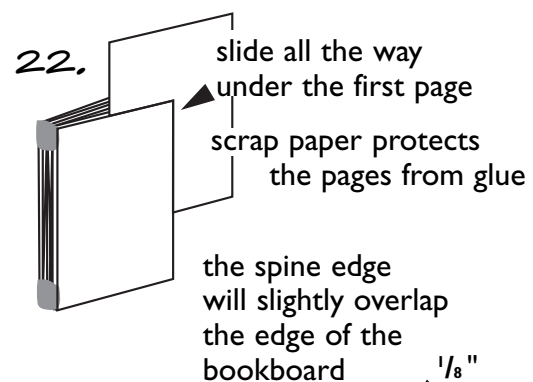
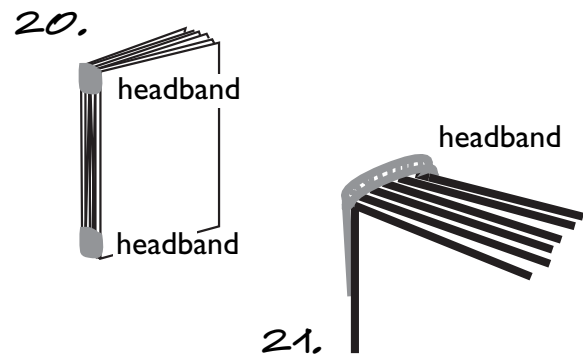

© 1999 Books By Hand

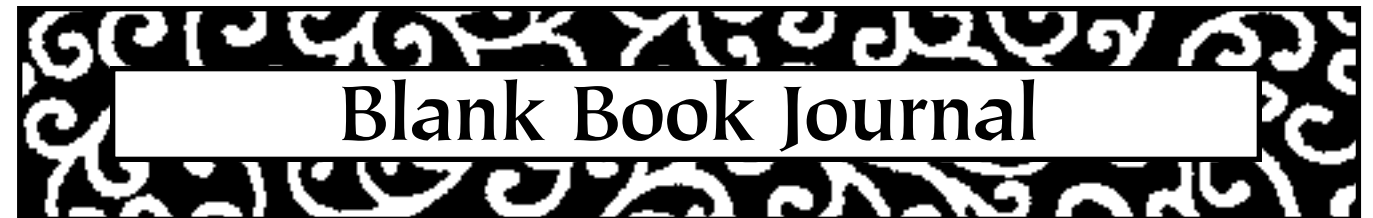

Blank Book Journal

FOR THIS PROJECT YOU WILL NEED:

- scissors or craft knife
- small glue brush, $\frac{1}{2}$ " wide
- larger glue brush, 1" to 2" wide
- pencil
- ruler
- PVA (good quality paper glue)
- scrap paper to glue on
- needle
- push pin or light duty paper awl
- wax paper to smooth out glued surfaces
- bone folder

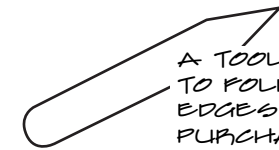

A TOOL USED BY BOOKBINDERS TO FOLD PAPER AND WRAP EDGES AROUND BOOKBOARD. PURCHASE AT HOBBY OR ART SUPPLY STORES.



TO PREPARE FOR THIS PROJECT:

Clear a work space and do an inventory of all the pieces in this kit. Carefully measure each piece. With a pencil, lightly label each piece with the capitalized letter that corresponds with the list below, figure 1.

STRUCTURE: Bookboard and pages

A two pieces-- $5 \frac{1}{8}$ " x $7 \frac{1}{8}$ " bookboard (front and back cover)

B one piece-- $5 \frac{1}{8}$ " x $7 \frac{1}{8}$ " heavy weight paper (the spine)

twenty-four pages*-- $10 \frac{1}{2}$ " x $6 \frac{7}{8}$ " acid-free, ivory colored paper (the “bookblock”)

* no need to mark these pages with a capitalized letter

COVER MATERIAL: Bookcloth is fabric backed with paper to create a glue barrier. Mark and glue only on the wrong, paper side.

C one piece-- $4 \frac{1}{2}$ " x $8 \frac{1}{8}$ " bookcloth (spine cover)

D two pieces-- $4 \frac{1}{2}$ " x $8 \frac{1}{8}$ " decorative paper (front and back cover)

HEADBAND: 100% cotton fabric with an embroidered bump along one edge--glue to top and bottom of the bound pages on the spine side (see figure 21)

LINEN THREAD: 48"--use to sew the pages together--withstands years of page turning

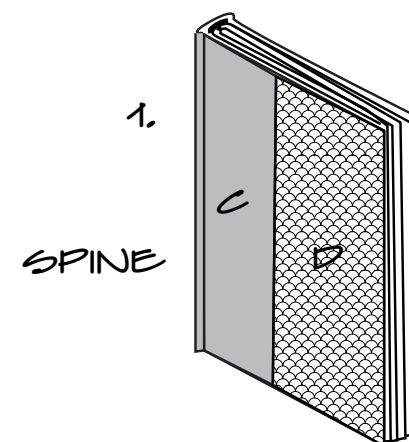

IMPORTANT!

Read and study the Glue Tips carefully before starting this project!

© 1999 Books By Hand





MAKING THE BOOKBLOCK: Begin with pages, needle, and linen thread.

- Definition: Folio: a single piece of paper folded in half, **figure 2**.
- Signature: a group of folios stacked inside one another, **figure 3**.
- Bookblock: consists of several signatures sewn and glued together, **figure 14**.

- create 24 folios by folding each piece of paper, with a bone folder, in half along the short dimension, **figure 2**.

- stack four folios inside one another, **figure 3**, to make six separate signatures.

- with a pencil, to designate the top edge, mark each signature somewhere with an arrow pointing up.

- make a template by marking a piece of scrap paper with the four lines as shown, **figure 4**, marking the top of the template with an arrow.

- matching up the template top and a signature top, lay the template along the fold of the inside of a signature, **figure 5**. Mark dots along the fold to correspond with the template marks. Repeat for all six signatures.

- using a push pin, punch a hole through an entire signature at each pencil dot along the fold. Be careful not to let paper move around. Repeat for all six signatures, **figure 6**.

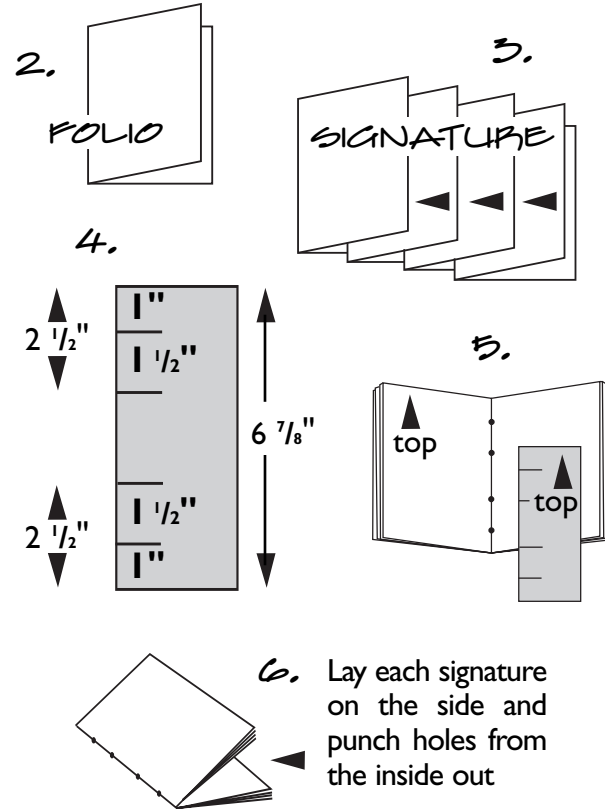

©1999 Books By Hand



SEWING THE SIGNATURES TOGETHER:

- Using a single strand of thread, sew the six signatures together as shown below.
- When adding a new signature, make sure to align the arrow mark with any previous arrow marks.
- Tighten the thread up as the signatures are sewn together.** Loose sewing is for illustration.

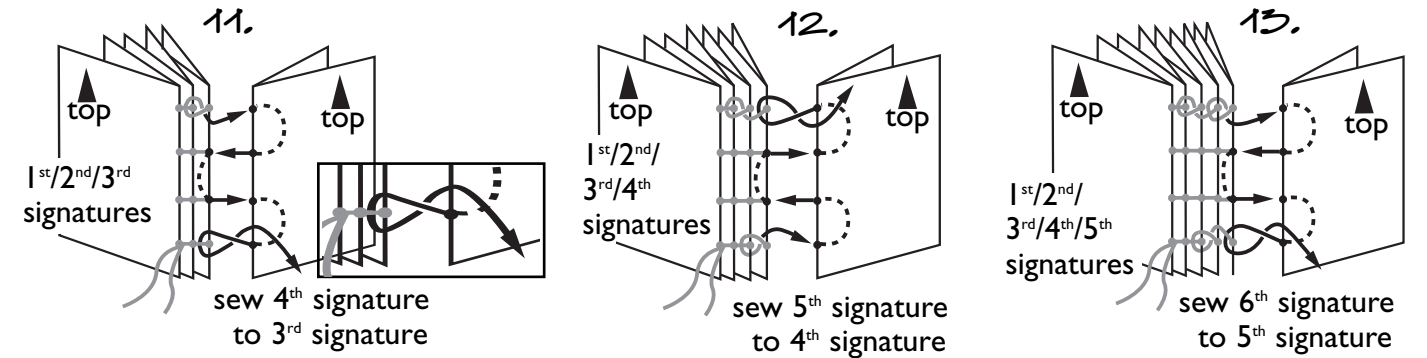
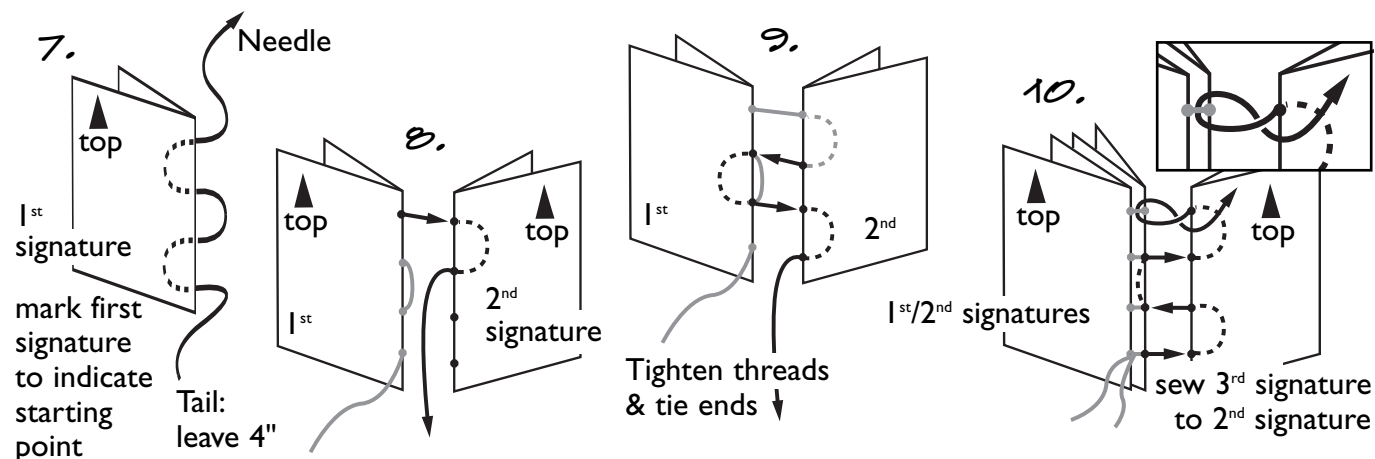

- after sewing on the last signature, knot the thread by sewing back through the previous stitching on the outside of the spine. Trim thread to four inches.

- apply a **heavy** layer of glue covering the entire outside of the spine, **figure 14**. Glue the two thread ends along the spine. Set aside to dry.

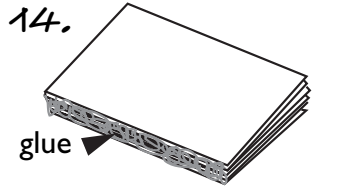

MAKING THE BOOK COVER: Use all of the remaining kit materials except for the cloth headbands.

- on the paper side of piece C, on the long dimension, use a ruler/pencil to mark the center, **figure 15**.

- center and glue spine, piece B, on the line, **figure 16**.

- measure 1/4" off each side of the spine piece and mark on the bookcloth, **figure 17**. Apply glue to the paper side of the bookcloth.

- glue down bookboard, piece A, along one of the pencil lines, centering the piece top and bottom, **figure 18**. Repeat for second piece A. Smooth bookcloth onto bookboard.

- apply glue and wrap bookcloth edges around bookboard and spine, **figure 18**.

- apply glue to the wrong side of a decorative paper, piece D, and move it to a clean surface, glue side up.

- close the outside cover. Hold at an angle to protect the bookcloth from the glue. Leaving approximately 1/2" on the top, bottom and side, rest a bookboard edge on the glue covered paper, **figure 19**. After adjusting the cover piece, carefully lower the cover onto the paper. The paper should overlap onto the bookcloth.

- clip corners, ✓ **Glue Tips**, and wrap edges. Repeat the last steps with the second piece D.

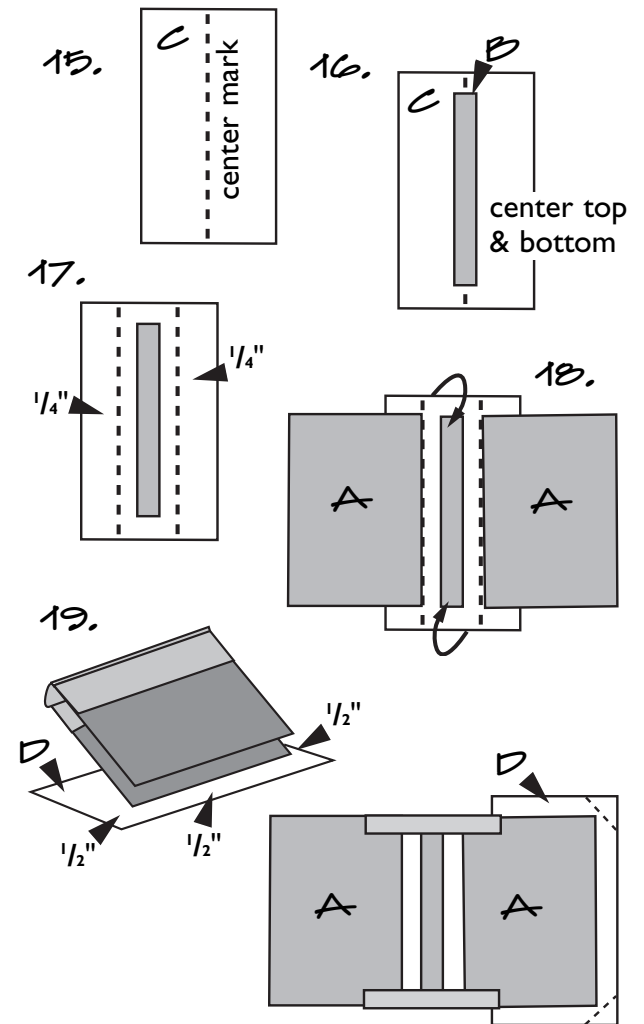

©1999 Books By Hand



We will send you a surprise if you let us know, in writing, about any typos or unclear instructions.